

EDRJ100 Installation Guide

Throttle Inhibit, RPM Increase/Decrease, Engine Start/Stop, Horn

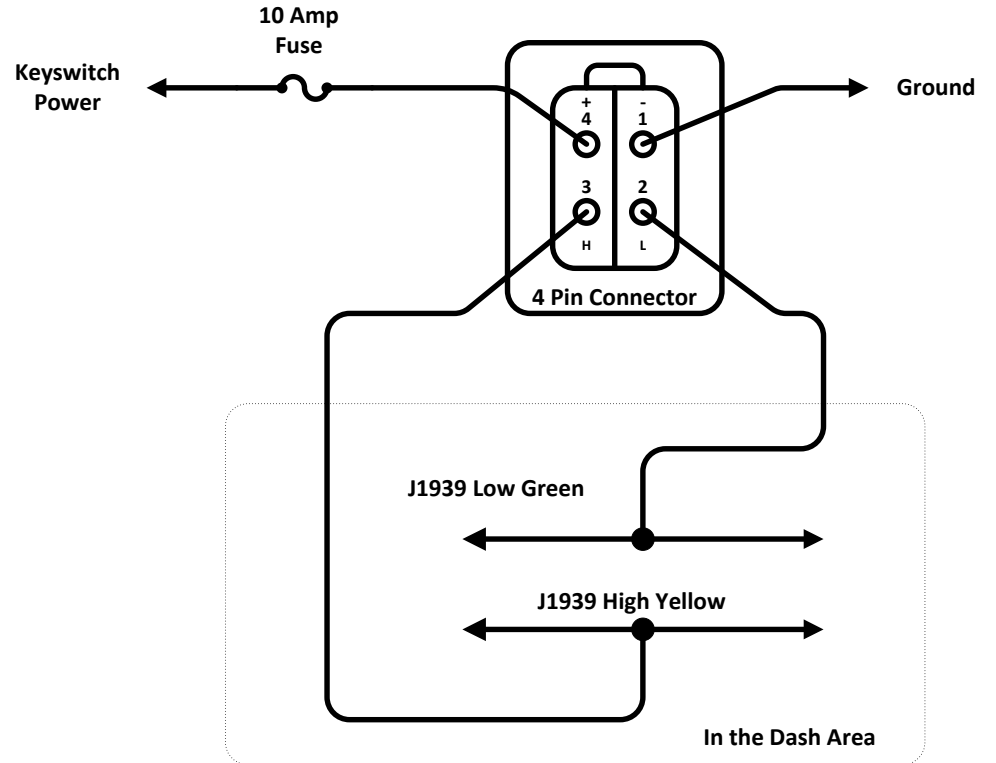
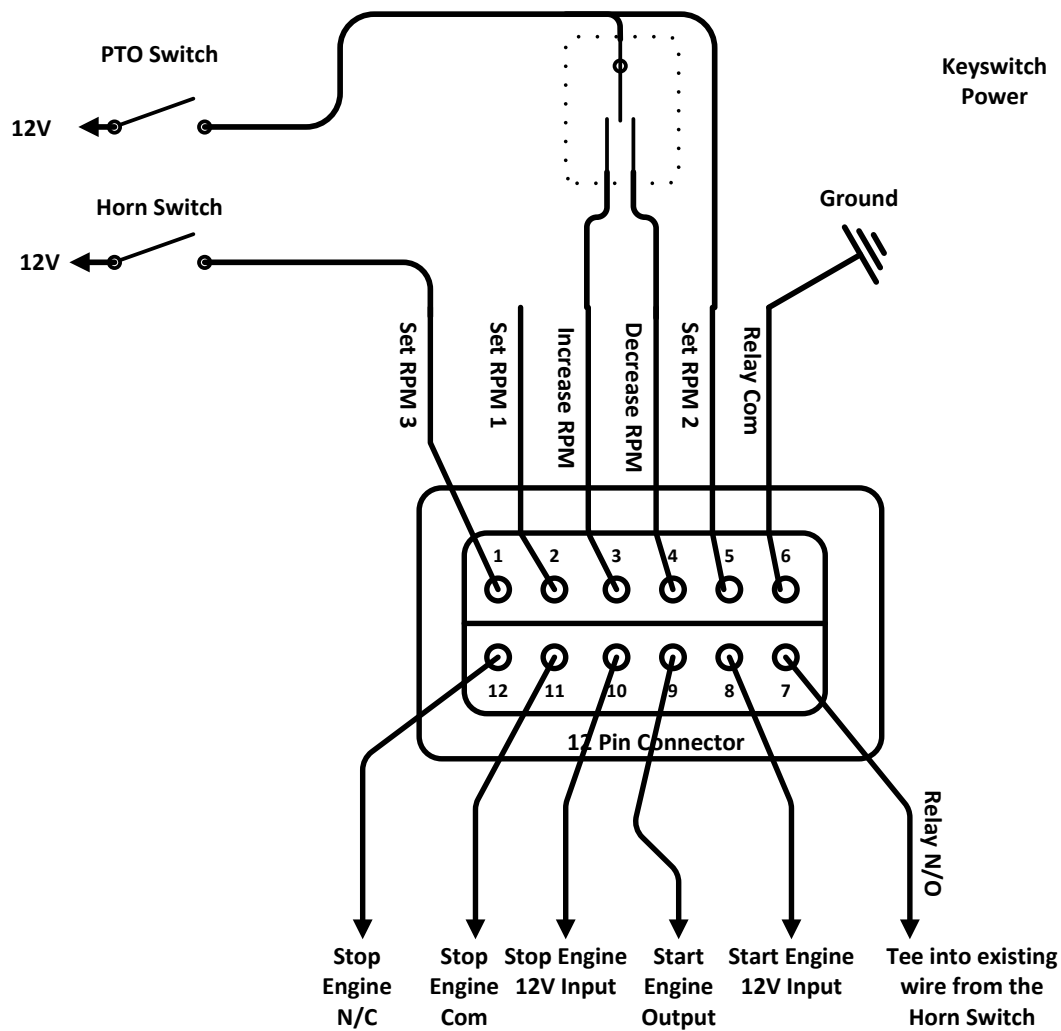

The J1939 wires are usually yellow and green. Refer to the ITF drawing for J1939 interface with the vehicle.

Note: It is important that you test this circuit after you make your connections, to make sure that the ohm reading between the High (Yellow wire) and Low (Green wire) is between 50 to 70 ohms. This is tested with the Keyswitch in the off position.